

BR30 Dimmable



ALTLED®
Asteria
Series

Specification Sheet

Product Introduction

ASTERIA is a minor planet that orbits the Sun, and also considered in the Greek Mythology as the Amazon that defeat the all mighty Heracles. ALT's ASTERIA can be presented as a strong, smart and efficient light bulb. ALT's Asteria BR Series is the most efficient and brightest LED for general lighting solution in the market, and is indeed the first high power LED to achieve the requirements in a safe, durable, and resourceful way. Concededly it is perfect for brightening up wide areas, including your living room, lobbies in Hotels, and dining areas in restaurants. Living wisely it allows you to reduce a considerable amount of energy consumption and maintenance costs, and at the same time provide a beautiful, elegant atmosphere. Simple and easy to install, also guaranteed by our engineers to last up to 40.000 hours, Asteria BR series are beautifully designed and will make a big difference in any ambient it is installed. More importantly, Asteria BR Series has been certified by the most important safety certification organisations, such as UL, TÜV, CE and FCC. All these provide a relieved safety environment to where it's applied.

Certificates



Features

- ✓ Adaptable solution for general dimmers in the market, one dimmer for multiple dimmable BR30.
- ✓ Elegant, rich and long-lasting lighting output ideal for Interior design.
- ✓ High density aluminum increase heat dissipation.
- ✓ Up to 90% energy saving compared to standard halogen lamp.

Application

- ✓ Shop Lighting
- ✓ Commercial Lighting
- ✓ Boutique Lighting
- ✓ Illumination Lighting
- ✓ Hotel Lighting



Specifications

Item	Specification	Details
Output	Beam Angle	60°, 72°, 120°
	Colour Range	TW / NW / WW
	Lumen Maintenance	40.000 hours
Electrical	Input Voltage	110 V AC / 220V AC
	Power Consumption	10 Watt
Physical	Bases	· E26 / 24 (US) · E26 / 27 (EURO)
	Weight	8.8 oz. (250 g)
	Lens	Optics PMMA
	Operating Temperature	-4° F to 104° F (-20°C to 40°C)
	Humidity	0 – 95%, non-condensing
Certification and Safety	Certifications	CE, FCC, LVD
	Environment	Not for use in totally enclosed fixtures Suitable for damp location
	Warranty	2 years
Two Million Worldwide Product Liability Insurance.		

Chipset Luminaries

Chipsets	Epistar
Power Consumption	10W
Beam Angle	60° / 72° / 120°
True White	○ CRI 70 400 lm
Natural White	● CRI 70 400 lm
Warm White	● CRI 70 300 lm

※All Chipset Luminaries Data are indicated in max values.

Optical Characteristics

Dominant Wavelength (nm) or Colour Temperature (K)

Correlated Colour Temperature	Min.	Typ.	Max.
True White	5650K	6500K	7000K
Natural White	3800K	4000K	5650K
Warm White	2670K	3000K	3800K

Illuminance at Distance

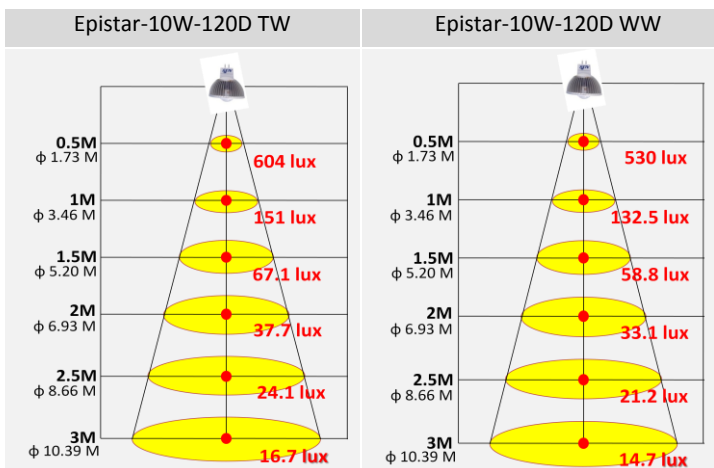

Mechanical Dimensions

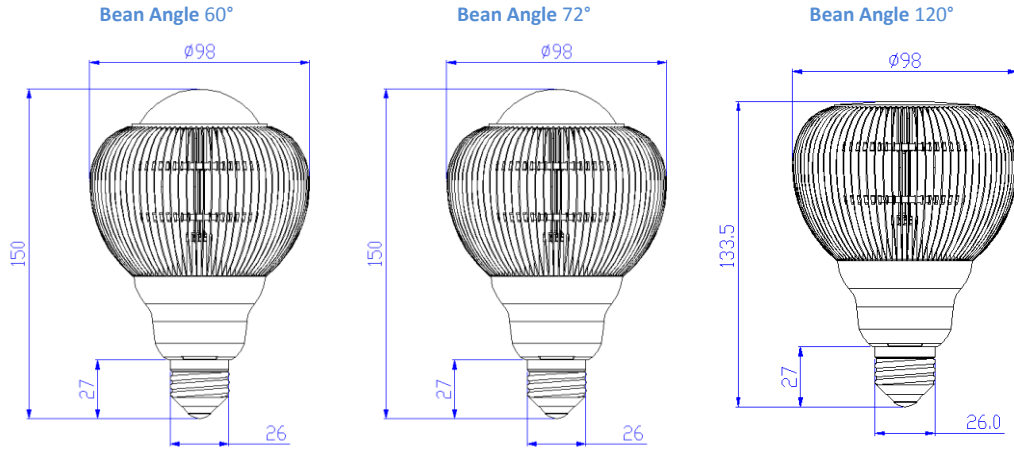

Copyright © Aeon Lighting Technology Inc. All rights reserved.

ALT and ALTED are either registered trademarks of Aeon Lighting Technology Inc. in Taiwan and/or other countries. All other brand or products names are trademarks or registered trademarks of their respective owners. Due to continuous improvement and innovations, specifications may change without notice.

Aeon Lighting Technology Inc.
16F-8., No.2, Jian 8th Rd., Chung-Ho City, Taipei
County 235, Taiwan (R.O.C.)
Tel +886-2-8226-1289
Fax +886-2-8226-9066
www.aeonlighting.com

